



Installing Euro-MERiDIAN "G" RANGE PANELS to meet the requirements of PD6662:2004

Engineer's reference guide software changes incorporated into Euro-MERiDIAN "G-Range panels (version 5.0), including installing and programming to comply with PD6662:2004

This document is intended to be a basic overview of the changes and how to use them to comply with new requirements. It is supplied as an addendum to the "software version 4" manuals whilst copies of the updated manual are awaited from printers.

Castle Care-Tech Ltd

North Street, Winkfield, Windsor, Berkshire, SL4 4SY

t Sales: 01344 887788 Technical Support 01344 886767

f 01344 890024 e sales@castle-caretech.com

www.castle-caretech.com

CONTENTS:

Section:	Page
1. Introduction	2
1.1 Terminology	3
1.2 Compliance Statement	3
2. System Components	4
3. System Architecture	4
4. Specifications	4
4.1 Zone map tables	5
5. The User Interface	6
6. Indications and Tones	8
7. Partitioning the System	8
8. Emergency Alarms	8
9. Remote Signalling	9
9.1. DD243:2004	9
10. Installation	9
11. Wiring	10
11.1 Detector wiring	10
11.2 Connection to ATE	12
12. Powering Up and Addressing Components	13
13. Basic Programming	13
14. Test and Diagnostic Features	15
15. System Logs	15
16. Summary of Programming Changes	16
Note: Sections 1 to 15 relate to corresponding chapters of the "Euro-MERiDIAN Engineering Manual"	

1. INTRODUCTION

Following the release of PD6662:2004, the entire Euro-MERiDIAN range has been upgraded to comply by release of Version 5.0 software. This takes into account also the requirements of DD243:2004, ACPO PA policy:2005 and the industry-agreed recommendations contained in BSIA "Form 171."

A number of product enhancements not relevant to PD.6662 have also been made and are included in these notes for completeness.

This guide summarises all changes that have been made and outlines how to make the installation fully compliant with the standards.

An 'Upgrade Software Module' may be used to upgrade an existing installed Euro-22, 28 or 44 system. This is a snap-in card, which fits into the MSX slot to upgrade the system software. Euro-134 and 256 systems may be upgraded by the use of a replacement MSX card.



Upgrading from earlier software issues to version 5.x will require full re-programming of the panel.

Options that need to be programmed into the panel to ensure the installation complies with new standards are identified in boxes. eg

ENGINEER MENU >> SITE OPTIONS >> Alert Keypads only>> [NO]

means that you should enter the engineer menu, select "Site Options" and change the "Alert Keypads only" item to NO.

1.1 TERMINOLOGY

Changes in terminology are required by the adoption of European standards. New terms have therefore been applied, as follows:

NEW TERM	Meaning	Corresponds with former
CIE	"Control & Indicating Equipment"	Control Panel
ATE	"Alarm Transmission Equipment"	Signalling equipment (STU / Digi)
ATS	"Alarm Transmission System" – includes ATE, transmission path and ARC receiver.	-
WD	Warning Device	Bell, Siren, Strobe, Speaker, etc
Notification	Passing of alarm indication to WD and/or to ARC	Includes "signalling"
Remote notification	Passing of alarm information to ARC.	Signalling
Hold Up (HU)	Personal Attack	PA
Input	Connections for wiring from detector, etc	"zone"
Zone	Term used in standards to apply to a system partition of any kind	NOT used in Euro-MERiDIAN

1.2 COMPLIANCE STATEMENT

Euro-MERiDIAN is suitable for use in systems designed to comply with PD6662:2004 at the following grades and environmental classes

	Security Grade	Environmental class
Euro-MERiDIAN G2	2	2
Euro-MERiDIAN G3+	3	2
Euro-MERiDIAN G2 fitted MSX G3 card and "Battery disconnect" module	3	2
External Set/Unset reader	3	4
Access Control Reader Head	Not applicable	4
Other peripheral devices	3	2

Relevant recommendations of BSIA Form 171 have been taken into account.

POWER SUPPLIES conform with the requirements of EN50131-6 (including the recommendations of BSIA Form 180) as under:

	Security Grade	Environmental class
Euro-MERiDIAN G2	2	2
Euro-MERiDIAN G3+	3	2
Euro-MERiDIAN G2 fitted MSX G3 card and "Battery disconnect"	3	2
Intelligent Power Supply	3	2

COM9600 DIGI-MODEM is suitable for use in systems designed for use with ATS levels 1 or 2 and environmental class 1 or 2. With the PSTN functioning normally, the ATS will comply with the required performance levels subject to the ARC being suitably equipped.

NOTE: This unit may be used for Downloading / Remote Servicing (ARM[®]) purposes in systems at ALL security grades.

2. SYSTEM COMPONENTS

Opportunity has been taken to re-structure the range. The part numbers have been adjusted to reflect this – full details are shown in the Price List. Please be careful to specify the correct part.

3. SYSTEM ARCHITECTURE

As a result of the re-structuring of the range, the system specifications, zone maps, etc have changed – full details are shown in the Engineering Manual.

4. SPECIFICATIONS

POWER SUPPLY RATINGS are specified for use with 17Ahr batteries, and vary according to the grading of the system in which they are used:

	Electrical Power Available	Rating Grade 1	Rating Grade 2	Rating Grade 3
G2	1.5A	1.25A	1.0A	-
G2 fitted MSX G3 card	1.5A	1.25A	1.0A	0.7A *
G3+	2.5A	1.25A	1.0A	0.7A
Intelligent PSU	2.5A †	1.25A	1.0A	0.7A

* - "Battery Disconnect Module" fitted in order to comply at grade 3.

† - When used for Access Control applications, the full electrical power may be used for a maximum of 15 seconds.

Note: Euro-MERiDIAN Power Supplies are NOT designed for use with multiple batteries connected.

4.1 INPUT LOCATION MAPS

Please note the following tables identifying the input locations for the new range of controls:

a) Panels used in End of Line (EOL) Mode:

Euro-	G2 EoL-16	MSX-G2- EoL-44	MSX-G2- EoL-134	MSX-G2- EoL-256	G3 PLUS 74	G3 PLUS MSX-134	G3 PLUS MSX-256
Inputs	16	44	134	256	74	134	256
EoL							
End Station	1-6	1-6	1-6	1-6	6	1-6	1-6
ZEM 0	7-14	7-14	7-14	7-14	7-14	7-14	7-14
ZEM 1	-	15-22	15-22	15-22	15-22	15-22	15-22
ZEM 2	-	23-30	23-30	23-30	23-30	23-30	23-30
ZEM 3	-	31-38	31-38	31-38	31-38	31-38	31-38
ZEM 4	-	-	39-46	39-46	39-46	39-46	39-46
ZEM 5	-	-	47-54	47-54	47-54	47-54	47-54
ZEM 6	-	-	55-62	55-62	55-62	55-62	55-62
ZEM 7	-	-	63-70	63-70	-	63-70	63-70
ZEM 8	-	-	71-78	71-78	-	71-78	71-78
ZEM 9	-	-	79-86	79-86	-	79-86	79-86
ZEM 10	-	-	87-94	87-94	-	87-94	87-94
ZEM 11	-	-	95-102	95-102	-	95-102	95-102
ZEM 12	-	-	103-110	103-110	-	103-110	103-110
ZEM 13	-	-	111-118	111-118	-	111-118	111-118
ZEM 14	-	-	-	119-126	-	-	119-126
ZEM 15	-	-	-	127-134	-	-	127-134
ZEM 16	-	-	-	135-142	-	-	135-142
ZEM 17	-	-	-	143-150	-	-	143-150
ZEM 18	-	-	-	151-158	-	-	151-158
ZEM 19	-	-	-	159-166	-	-	159-166
ZEM 20	-	-	-	167-174	-	-	167-174
ZEM 21	-	-	-	175-182	-	-	175-182
ZEM 22	-	-	-	183-190	-	-	183-190
ZEM 23	-	-	-	191-198	-	-	191-198
ZEM 24	-	-	-	199-206	-	-	199-206
ZEM 25	-	-	-	207-214	-	-	207-214
ZEM 26	-	-	-	215-222	-	-	215-222
ZEM 27	-	-	-	223-230	-	-	223-230
ZEM 28	-	-	-	231-238	-	-	231-238
K'PAD 00	15-16	39-40	119-120	239-240	63-64	119-120	239-240
K'PAD 01	-	41-42	121-122	241-242	65-66	121-122	241-242
K'PAD 02	-	43-44	123-124	243-244	67-68	123-124	243-244
K'PAD 03	-	-	125-126	245-246	69-70	125-126	245-246
K'PAD 04	-	-	127-128	247-248	71-72	127-128	247-248
K'PAD 05	-	-	129-130	249-250	73-74	129-130	249-250
K'PAD 06	-	-	131-132	251-252	-	131-132	251-252
K'PAD 07	-	-	133-134	253-254	-	133-134	253-254
K'PAD 08	-	-	-	255-256	-	-	255-256

b) Panels used in iD Mode:

Euro-	G2 iD-16	MSX-G2- iD-44	MSX-G2- iD-134	MSX-G2- iD-256	G3 PLUS 74	G3 PLUS MSX-134	G3 PLUS MSX-256
Inputs	24 *	44	134	256	74	134	256
iD inputs							
End Station	1-10	1-30	1-30	1-30	1-30	1-30	1-30
ZEM 0	-	-	31-60	31-60	31-60	31-60	31-60
ZEM 1	-	-	61-90	61-90	-	61-90	61-90
ZEM 2	-	-	91-120	91-120	-	91-120	91-120
ZEM 3	-	-	-	121-150	-	-	121-150
ZEM 4	-	-	-	151-180	-	-	151-180
ZEM 5	-	-	-	181-210	-	-	181-210
ZEM 6	-	-	-	211-240	-	-	211-240
EoL Inputs							
End Station	-	-	-	-	61-66	121-126	241-246
ZEM 0	11-18 *	31-38 *	-	-	-	-	-
ZEM 1	-	-	-	-	-	-	-
K'PAD 00	19-20	39-40	121-122	241-242	67-68	127-128	247-248
K'PAD 01	21-22	41-42	123-124	243-244	69-70	129-130	249-250
K'PAD 02	23-24	43-44	125-126	245-246	71-72	131-132	251-252
K'PAD 03	-	-	127-128	247-248	73-74	133-134	253-254
K'PAD 04	-	-	129-130	249-250	-	-	255-256
K'PAD 05	-	-	131-132	251-252	-	-	-
K'PAD 06	-	-	133-134	253-254	-	-	-
K'PAD 07	-	-	-	255-256	-	-	-

NOTE * - ZEM 0 in a G2/16 iD system OR MSX-G2-44 system used in iD mode is a RADIO ZEM. This is programmed as if used for EOL inputs.

5. THE USER INTERFACE

To comply with the new requirements, the following changes have been made to the user interface:

a) Engineer Restore functions

When "engineer restore" is required, this will be identified in the "Alert" menu – see section 6 – not permanently displayed. The "Engineer restore" operation may be carried out without the entire system having been unset.

To perform an "anticode reset" (if this has been enabled in the programming section) enter the USER/MANAGER menu, and select the "anticode restore" option. This will show the appropriate code that can be decoded to provide an anticode to perform the restore operation.

NOTE: To comply with the new requirements, a new "anticode" algorithm is used. This will require updating of your decoding software AND THAT AT THE ARC.

b) SETTING WITH FAULTS

Attempts to set the system will be blocked if ANY of the following conditions exist:

- Detector in active condition
- Tamper condition exists
- Fault (PSU, WD, ATS, etc.) exists on the system
- Masking condition exists (grade 3)

The presence of this condition will be indicated on the display and the "alert" tone will sound.

Active detectors may be omitted by the user IF they are programmed with the "omittable" attribute. Over-riding of other conditions is **grade-dependent**, and may be selected thus:

ENGINEER MENU >> SITE OPTION >> Set with Fault>> [YES]
ENGINEER MENU >> SITE OPTION >> Set with Tamper +>> [NO] (see note)
ENGINEER MENU >> SITE OPTION >> Set with ATS Fault>> [YES]
ENGINEER MENU >> SITE OPTION >> Set Ward TF>> [YES]

NOTE: Setting with tamper condition present is not permitted at Grade 3 - but is NOT recommended at any grade.

c) USER / MANAGER MENU

The previous "Manager Menu" structure has been completely replaced by a new User / Manager menu.

This is available to ALL users / managers by pressing the "D" key immediately before entering their code (or tag). This provides ALL code-holders with the ability to change their own code, to perform basic system test functions, view logs, carry out "anticode restore" and to authorise engineer access to the system.

Holders of Manager codes have additional capability to manage system users, and perform other functions present in the former "manager menu." Additional functionality – including the ability to manage SMS message numbers – has also been included.

Managers may allocate to other users ONLY those areas / levels to which they have themselves been permitted access.

ALL Manager codes (including Master Manager) have the capability to set / unset the system.

NOTE: default for Master Manager Code remains OFF. If required to set / unset:

MANAGER MENU >> Change codes>>Change Master Manager code >> set /unset
--

d) Code Guessing

Code guessing no longer generates a tamper alarm. The operation is: Following 23 incorrect key-presses (or 6 incorrect tags), an "alert" response will be generated and the keypad (or tag reader) will be DISABLED for 90 SECONDS. At the end of this period, it will be re-enabled, but will again be disabled for a further 90 seconds after EACH further 6 key-presses or 1 tag entry until restored by a correct code / tag.

6. INDICATIONS AND TONES

"ALERT" is the ONLY indication permitted without entry of a valid code (or tag) except for those incidental to entry / exit procedures.

Accordingly, the "Power" indication has been removed and replaced by an "ALERT" indication, which functions as follows:

If a condition exists that requires the attention of a user, an ALERT TONE will sound and the ALERT INDICATION will flash.

On entering a valid code (or tag), the relevant information will be displayed on the LCD screen, coupled with the "Fault / Tamper / Alarm LEDs to indicate the type of information being displayed. If the "Alert" indicator continues to show, it will indicate that additional information is also available, the may be accessed by scrolling the display with the "YES" key.

The display will clear when the YES key is pressed after the last item of information has displayed, or after 3 minutes. If the condition giving rise to the "alert" has NOT yet cleared, the "alert" indication will remain (silently) until the condition has been cleared AND the display again viewed.

PROGRAMMING:

By default, the alert tone will be present on keypads only. To have this present also on system loudspeakers:

ENGINEER MENU >> SITE OPTION >> Alert Keypads only>> [NO]

7. PARTITIONING THE SYSTEM

There are no changes affecting this section.

8. EMERGENCY ALARMS

Please note that expected changes to Police policy scheduled for implementation on 1st October 2005 will ban the signalling of "Duress" alarms for police response. The Euro-MERiDIAN keypad will NOT be acceptable for the generation of "2-key PA" alarms intended for police response according to the new criteria.

9. REMOTE NOTIFICATION

There is a mandatory 30 second (minimum) delay between the end of entry time (when WDs become live) and the commencement of alarm signalling to the ARC. This is set by the "Pre-Alarm Timer."

ENGINEER MENU >> TIMERS >> Pre-Alarm Time>> [30]

9.1 DD243:2004

For full details of DD243:2004 requirements, see separate notes.

For compliance with the adjusted clause 6.4.5, the "Prevent PIN codes" option has been replaced with:

ENGINEER MENU >> SITE OPTIONS >> Restrict PIN use>> [YES]

Selection of this will prevent the system from responding to PIN codes during entry time. PIN codes can be programmed as normal. There is no longer a need to use "Guard Codes" to unset outside of this time if the tag is lost / damaged.

Other related changes are:

- a) In the event of entry taking place during the period between the end of "siren time" and the end of "confirmation time," normal entry time will apply – NOT the generation of a local alarm as with previous software issues.
- b) ENTRY SHOCK inputs will now trigger an immediate alarm in the event that the final exit door is opened within 10 seconds of the shock zone being triggered. The confirmation requirements after this trigger are unchanged.
- c) FLEXI-UNSET: Additional site option to permit selection of individual areas when unsetting.

ENGINEER MENU >> SITE OPTIONS >> Flexi-Unset?>> [YES]

NOTE: This option is NOT suitable for use with systems unsetting in accordance with DD243:2004 clause 6.4.5

10. INSTALLATION

Over a period of time, new printed circuit boards will be phased in, using adjusted terminal legends, etc. – details will be provided with the equipment as this is introduced.

11. WIRING

11.1 DETECTOR WIRING

No changes are required for grade 1 and 2 systems.

However, at Grade 3, additional messages will be passed from detectors to indicate **MASKING** and **FAULT** conditions.

Availability of "fault" signals from detectors is NOT mandatory until TS50131-2-x standards are called up by an update to PD6662:2004. However, detectors will begin to be manufactured to comply with the additional requirements in advance of that, so you may encounter detectors with any of the following combinations of terminations - all compliant with PD6662:2004!!!

Tamper + Intrusion + Masking

Tamper + Intrusion + Fault + Masking

Tamper + Intrusion + Fault **

** in this case, signalling of Masking is by a combination of Intrusion and Fault signals.

Any mix of these types may be used on Euro-MERiDIAN, as follows:

a) END OF LINE INPUT WIRING

Additional resistors are used as follows, so that each detector requires a single input at the control.



Note: THIS FUNCTIONALITY IS NOT AVAILABLE ON PERIPHERAL DEVICES FITTED SOFTWARE EARLIER THAN VERSION 5.0.

In such cases, detectors must use "paired" inputs, as described at c).

(i) If detector has tamper, alarm and mask terminals:

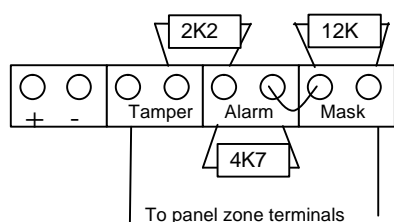

(ii) If detector has tamper, alarm and fault terminals:

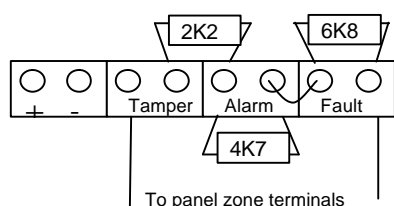

(iii) If detector has tamper, alarm, mask and fault terminals:

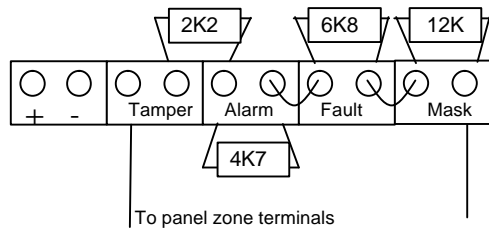

In all cases, the 2K2 resistor **MUST** be located at the furthest point on the wiring circuit, or the wiring security it provides will be lost.

Resistor colour code:

- 2K2 – Red / Red / Red / Gold
- 4K7 – Yellow / Purple / Red / Gold
- 6K8 – Blue / Grey / Red / Gold
- 12K – Brown / Red / Red / Gold

b) ID PLUS WIRING

Note that only 2 pieces of information can be reported by each biscuit, therefore **TWO** biscuits will be required per grade 3 detector, programmed as shown at **c)**, and wired as follows:

(i) If detector has tamper, alarm and mask:

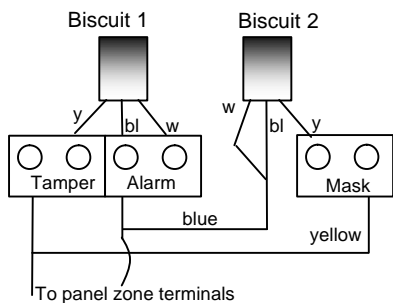

(ii) If detector has tamper, alarm and fault terminals:

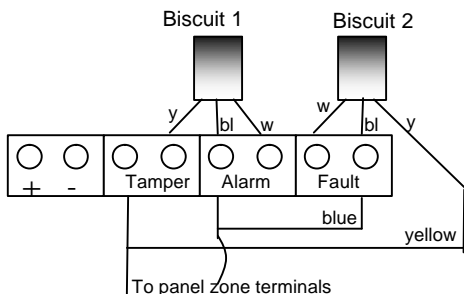

(iii) If detector has tamper, alarm, mask and fault terminals:

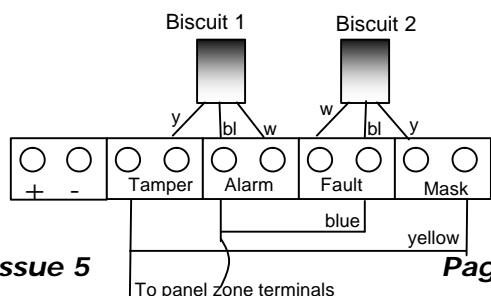

c) INPUT PAIRING

Because two biscuits are required for Grade 3 detectors, the biscuits must be paired with each other in panel programming.

ENGINEER MENU >> CHANGE INPUTS? >> Input n>> [YES] >> As follows..

(i) Input used for FIRST BISCUIT (alarm + tamper):

Input Type	Select as appropriate.
Scroll to	
Paired Input?	Set to 'Yes'
Fault Input?	Leave at 'No'
Paired With (00)	Insert number of Input used for 2 nd biscuit.

(ii) Input used for SECOND BISCUIT (fault + masking):

Input type	Set to FAULT [16]
Scroll to	
Paired Input?	Set to 'YES'
Fault Input?	Set to 'Yes'
Paired with (00)	Insert number of input used for 1 st biscuit.

Note: This same technique may be used if peripherals fitted with software earlier than v5.0 are used in EOL systems.

11.2 CONNECTION TO ATE

a) The ATE outputs now default as 0v when active (ie POSITIVE REMOVED). In order to use positive applied signalling:

ENGINEER MENU >> SITE OPTIONS >> Invert ATE Outputs>> [NO]

b) Where the COM9600 is used for signalling to the ARC, it must be programmed to meet the ATS "reporting" requirement as under:

ENGINEER MENU >> SET UP DIGI/SMS? >> Test Calls>> [YES]>>Daily
(see Engineering Manual Chapter 21).

c) Additional signals are required to the ARC for compliance with the new requirements. There are also additional requirements for the display of ATS path fault information to the user.

A new protocol has therefore been agreed by the industry for the exchange of information between CIE and ATE, identified as "BSIA Form 175." ***Euro-MERiDIAN is fully compliant with this agreement when used with fully compliant ATE.***

NOTE: Plug-on devices do not permit the full number of channels permitted by Form 175 to be triggered via the pins, therefore additional terminal to terminal connections will be required. For this purpose, G3+ End Station output 3 is defaulted as "Mains Fail [0052]" and output 4 as "Global Fault 2 [0056]" A 1K resistor is required from Output 3 to +12v to ensure correct operation.

The new default outputs for connection to ATE (taking into account also the requirements of DD243:2004) are therefore:

O/P No:	Grade 2	Grade 3	G2 \$\$ Loom colour	G3+ Plug-on Pin No.
1	Fire [0001]	Fire [0001]	Green	1
2	HU Device [0009]	HU Device [0009]	Grey	2
3	Unconfirmed [0018] *	Unconfirmed [0018] *	Mauve	3
4	Final Set ANY [0022] (For level Set systems)	Final Set ALL [0004]	Black	4
5	Tamper [0007] #	Tamper [0007]	Yellow	5
6	Confirmed [0006]	Confirmed [0006]	Blue	13
7	Omit Rearm [0017]	Omit Rearm [0017]	2 nd White	14
8	-	ATE Not Used [0066] §	2 nd Grey	16
9	Global Fault 1 [0055]	ATE Not Used [0066] §	2 nd Black	8
10†	Test ATS [0064]	Test ATS [0064]	2 nd Mauve	11

\$\$ - These outputs are live ONLY if an MSX card is fitted to the G2 ES.

* "Unconfirmed" signal triggers for both "Intrusion" AND "Tamper" activations when the system is set to permit correct ARC response.

Tamper signal is OPTIONAL at grade 2

§ This output type should NOT be changed, or problems may be experienced with operation of ATE - UNLESS "+ive applied" triggering is selected (SITE OPTIONS >> INVERT ATE OUTPUTS >> NO), in which case they should be changed to type 0000 (Not Used)

† "Test ATS" signal is required for ALL dual path signalling devices, and is also used by "ARM[®]" software functions.

Changes should be made as necessary:

ENGINEER MENU >> CHANGE OUTPUTS >> ATE Op n >> [xxxx] (as required)

12. POWERING UP and ADDRESSING COMPONENTS

Certain components – eg ZEMs – will be revised so that more can be used on the system. The number of available addresses will therefore increase – see details supplied with relevant equipment.

13. PROGRAMMING THE BASICS

a) ENTERING THE ENGINEER MENU

Access to engineering functions is permitted ONLY if authorised by a user or manager. This is performed as follows:

USER/MANAGER MENU >> ALLOW ENGR MENU? >> [YES]
--

Once selected, this remains valid until removed by a user / manager. Access is prevented if this option is not correctly set – or if the system is not fully unset.

b) TEXT PROGRAMMING

The allocation of characters to keys has been changed to reflect those commonly used on mobile telephones. Full details are shown in both Installation and user manuals.

c) CLEAN START

Additional options are included in the "Clean Start" menu.

These permit a clean start to be made WITHOUT clearing user codes / tags. After a clean start has been carried out, logs may be cleared.

d) MODE SELECTION

The default "Zone response" time is now 400mS – the highest permitted by the new standards.

e) INPUT PROGRAMMING

Additional input types are available for "fault" applications in grade 3 systems, and for use with "pulsed" keyswitch (or similar) inputs

Additional attribute provided for "input-pairing" purposes – see 11 c).

For new "input location maps," refer section 4.1

f) TIMERS

New limits are imposed on certain timer functions:

ENTRY TIME: Maximum 45 seconds

SIREN TIME: Minimum 90 seconds (Euro-MERiDIAN 2 minutes)
Maximum 15 minutes.

g) SYSTEM DISPLAYS

Only "display when set" – providing indication of the "set" status of the system AND of current alarm states – is now available.

NOTE: Use of this option is NOT compliant with PD6662:2004.

h) CHANGE CODES

An additional option is provided for compliance of Grade 3 systems with the requirement for number of differs:

ENGINEER MENU >> CHANGE CODES >> 5 digit PINs>> [YES]
--

When selected, ALL programmed codes must be at least 5 digits long.

i) VOLUME LEVELS

Please note that the audible chime available on exit tone when set at volume level 1 is now available at ALL volume levels (except 0), and will take place at the end of "SETTLE" time.

j) PROGRAMMING OUTPUTS

Additional output types are available, as itemised in the installation manual and some defaults are adjusted (see also section 9 for signalling changes).

k) INTELLIGENT SETTING

More than one detector may now be programmed to perform the "switch" when intelligent setting is used.

l) SITE OPTIONS

Additional / Changed site options are provided:

Over-riding of "prevention of set" – see section 5.

"Restrict PIN use" – see section 9.1

"Flexi-Unset" – see section 9.1

m) ENGINEER RESTORE

This is MANDATORY only for TAMPER alarms at grade 3 for compliance with PD6662:2004.

However, UK police requirements specify that it should be applied to ALL alarms passed to them (other than Hold Up), and should therefore be applied to "CONFIRMED" alarms at all grades. An addendum to PD6662:2004 is anticipated to clarify this.

Grade 3:

ENGINEER MENU >> ENGINEER RESTORE OPTIONS? >> Eng Restore Tamp>> [YES]

ALL grades:

ENGINEER MENU >> ENGINEER RESTORE OPTIONS? >> Eng Restore Conf>> [YES]

14. TEST & DIAGNOSTIC FEATURES

"Walk Test" and "Siren Test" facilities are now provided in the User / Manager menu for ALL users.

An additional facility is available for testing the operation of an SAB. Output types (0043 and 0044) are provided which change state ONLY when triggered in the Engineer "Test Outputs" menu. Type 0043 becomes active when tested, type 0044 is active except when tested.

An output programmed to one of these configurations may thus be used to trigger a relay to break the hold-off connection to the SAB – or even to provide the hold-off directly (ensure that sufficient current is available).

15. SYSTEM LOGS

The logging structure has been completely changed to comply with the requirements of the new standards. Visible changes are:

- a) The separation of "USER" and "ENGINEER" logs has been abolished.
- b) Clearing of logs is no longer permitted – and can be carried out ONLY after a clean start has been performed.

Access to system logs is available in the User / Manager menu for ALL users, and does NOT require the system to be fully unset or an engineer reset to be performed in order to view.

16. SUMMARY OF INSTALLATION CHANGES:

The vast bulk of the changes required by the new standards are taken care of within the equipment design. This leaves only the following changes to be made during installation / programming when compared to previous BS4737 installations:

	BS4737	ADDITION / CHANGE			See
		Grade 1	Grade 2	Grade 3	
Codes	4-digit	No change	No change	5-digit	13h
Detector Wiring	D/Pole EOL iD	No change	No change	Anti-Masking, and Fault connections EOL : additional resistors iD : biscuit pairing.	11.1
Engineer Restore	Confirmed	No change	No change	Also Tamper	5c, 13m
Notification	Current formats	No change	Global Fault (when set)	Global Fault (always) and Tamper	11.2
Digi Test call	-	Daily test call required		Not suitable	11.2

The following table is provided as guidance for the provision of battery back up for the installed system:

Power available from system battery for required time:					
	BS4737	Grade 1	Grade 2	Grade 3	
Time:	8 hours	12hours	12 hours	24 hours	12 hours (if signal MF)
7 AHr Batt	750mA	500mA	500mA	250mA	500mA
17AHr Batt	2A	1.25A	1A	700mA	700mA

NOTE: If the specified 17 AHr battery is used, there is no practical benefit from signalling "Mains Fail" to the ARC - the method of specifying the power supply rating per EN50131-6 ensures that 24 hours back up at full system load will be available. "Mains Failure" will in any event be signalled as part of the mandatory "global fault" signal.